



Standard Test Method for Vicat Softening Temperature of Plastics¹

This standard is issued under the fixed designation D 1525; the number immediately following the designation indicates the year of original adoption or, in the case of revision, the year of last revision. A number in parentheses indicates the year of last reapproval. A superscript epsilon (ϵ) indicates an editorial change since the last revision or reapproval.

This standard has been approved for use by agencies of the Department of Defense.

1. Scope *

1.1 This test method covers determination of the temperature at which a specified needle penetration occurs when specimens are subjected to specified controlled test conditions.

1.2 This test method is not recommended for ethyl cellulose, nonrigid poly(vinyl chloride), poly(vinylidene chloride), or other materials having a wide Vicat softening range.

1.3 The values stated in SI units are to be regarded as the standard.

1.4 *This standard does not purport to address all of the safety concerns, if any, associated with its use. It is the responsibility of the user of this standard to establish appropriate safety and health practices and determine the applicability of regulatory limitations prior to use.*

NOTE 1—This test method and ISO 306:1987(E) are technically equivalent, with the exception of the allowance for creep, prior to beginning the test, in this test method.

2. Referenced Documents

2.1 ASTM Standards:

D 618 Practice for Conditioning Plastics and Electrical Insulating Materials for Testing²

D 648 Test Method for Deflection Temperature of Plastics Under Flexural Load²

D 883 Terminology Relating to Plastics²

D 1898 Practice for Sampling of Plastics²

E 1 Specification for ASTM Thermometers³

E 77 Test Method for the Inspection and Verification of Thermometers³

E 220 Test Method for Calibration of Thermocouples by Comparison Techniques³

E 644 Test Methods for Testing Industrial Resistance Thermometers³

E 691 Practice for Conducting an Interlaboratory Study to

Determine the Precision of a Test Method⁴

E 1137 Specification for Industrial Platinum Resistance Thermometers³

2.2 ISO Standards:⁵

ISO 291 Plastics—Standard Atmospheres for Conditioning and Testing

DIS 306 Plastics—Thermoplastic Material—Determination of Vicat Softening Temperature

3. Terminology

3.1 *Definitions*—Definitions of plastics used in this test method are in accordance with those defined in Terminology D 883, unless otherwise specified.

3.1.1 *Vicat softening temperature*—the temperature at which a flat-ended needle of 1-mm² circular cross section will penetrate a thermoplastic specimen to a depth of 1 mm under a specified load using a selected uniform rate of temperature rise.

4. Summary of Test Method

4.1 A flat-ended needle loaded with a specified mass is placed in direct contact with a test specimen. The mass applied can be one of two accepted loads, as follows:

Loading 1— 10 ± 0.2 N

Loading 2— 50 ± 1.0 N

The specimen and needle are heated at either of two permissible rates, as follows:

Rate A— $50 \pm 5^\circ\text{C/h}$

Rate B— $120 \pm 10^\circ\text{C/h}$

The temperature at which the needle has penetrated to a depth of 1 ± 0.01 mm is recorded as the Vicat softening temperature.

5. Significance and Use

5.1 Data obtained by this test method may be used to compare the heat-softening qualities of thermoplastic materials.

¹ This test method is under the jurisdiction of ASTM Committee D20 on Plastics and is the direct responsibility of Subcommittee D20.30 on Thermal Properties (Section D20.30.07).

Current edition approved March 10, 2000. Published May 2000. Originally published as D 1525 – 58T. Last previous edition D 1525 – 98.

² *Annual Book of ASTM Standards*, Vol 08.01.

³ *Annual Book of ASTM Standards*, Vol 14.03.

⁴ *Annual Book of ASTM Standards*, Vol 14.02.

⁵ Available from American National Standards Institute, 11 W. 42nd St., 13th Floor, New York, NY 10036.

*A Summary of Changes section appears at the end of this standard.

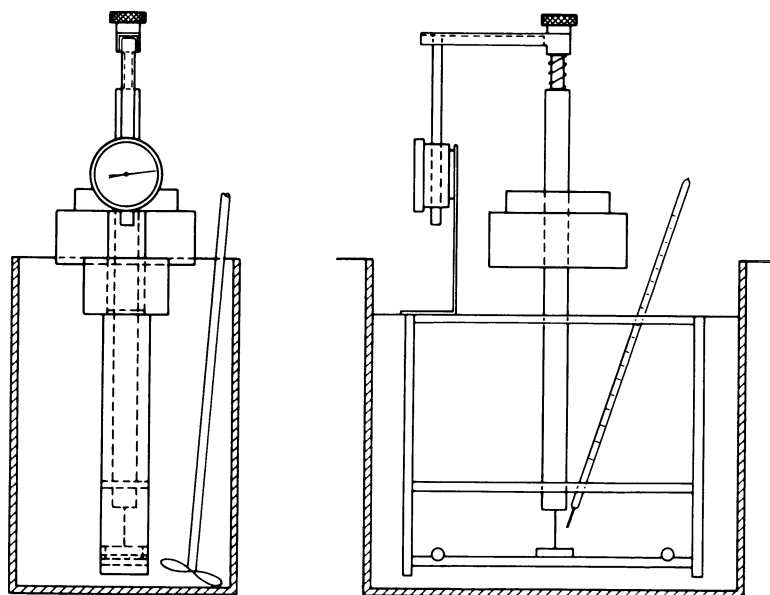

FIG. 1 Apparatus for Softening Temperature Determination

5.2 This test method is useful in the areas of quality control, development, and characterization of plastic materials.

6. Apparatus

6.1 The equipment shall be constructed essentially as shown in Fig. 1 and shall consist of the following:

6.1.1 *Immersion Bath*—The bath containing the heat-transfer medium shall be equipped with a stirrer, temperature-measuring device, and heater. The heater shall have automatic control of the selected bath temperature-rise rate (see 4.1). The bath should be constructed to allow the specimens to be submerged at least 35 mm below the surface of the heat-transfer medium.

6.1.2 *Heat-Transfer Medium*—Several liquids, such as silicone oils, glycerine, ethylene glycol, and mineral oil have been used successfully for various plastics.⁶ The medium used shall be free from contaminants and shall have no short-time effect at elevated temperatures on the material being tested, and shall be of low viscosity at room temperature. The results of the test may depend on the thermal diffusivity of the heat-transfer medium.

NOTE 2—It is desirable to have a method of cooling the bath in order to reduce the time required to lower the temperature of the bath between tests. This may be accomplished by using a cooling coil installed in the bath or an external heat-transfer system. If the temperature rise rate is adversely affected by the presence of residual coolant in the cooling coils, the coolant should be purged prior to beginning the test.

6.1.3 *Specimen Support*—A suitable stand or support for the specimen to be placed in the bath. The vertical members that attach the specimen support to the upper plate shall be made of a material having the same coefficient of expansion as that used for the rod through which the load is applied in order that the penetration-measuring device reading caused by differential

expansion over the intended temperature range does not exceed 0.02 mm when the specimen is replaced by a piece of heat-resistant material.⁷

6.1.4 *Penetration-Measuring Device*—The device used for measuring the penetration of the specimen shall be capable of measuring a penetration depth of at least 1 ± 0.01 mm. The measuring device may be an analog or digital dial gage or similar device, including an electronic-displacement sensing apparatus.

6.1.5 *Masses*—A set of masses of suitable sizes shall be supplied so that the net force on the needle point shall be equal to 10 ± 0.2 N (Loading 1) or 50 ± 1.0 N (Loading 2) when the apparatus is assembled. The net force shall consist of the weight of the needle rod assembly, the force attributed to action of the penetration-measuring device, and the extra weight that is required to balance the system. The required mass is calculated as follows:

$$\text{Required mass, } m_w = (F - F_s)/9.80665 - m_r$$

- F = total force to be applied to the specimen, N,
- F_s = force exerted by any penetration-measuring device, N (this is a positive value if the thrust of the spring is towards the specimen (downward), a negative value if the thrust of the spring is opposing the descent of the rod, or zero if no such device is involved),
- m_r = mass of the needle rod assembly, kg, and
- m_w = extra mass applied to attain the desired force, kg.

Verification of the load should be made on new equipment and after replacing penetration-measuring devices, or at any time to ensure that the equipment is in calibration. The calibration procedure for dial-gage-type penetration-measuring devices is described in Appendix X1 and Appendix X2. The

⁶ Silicone oils having a room temperature viscosity of 100 cP have been found satisfactory and safe for short-term heat cycles up to 260°C.

⁷ Borosilicate glass has been found satisfactory for this purpose.

methods for determination of the thrust contributed by dial-gage-type penetration-measuring devices are also given in Appendix X1 and Appendix X2.

6.1.6 *Temperature-Measuring Device*—A thermocouple, resistance thermometer (RTD), or thermometer adequate to cover the range being tested. The thermometer shall be one of the following, or its equivalent, in accordance with Specification E 1: Thermometer 1C or 2C, having ranges from -20 to 150°C or -5 to 300°C , respectively, depending on the test range. The thermocouple or resistance thermometer and related electronics shall be accurate to at least $\pm 0.5^{\circ}\text{C}$. Mercury-in-glass thermometers shall be calibrated for the depth of immersion in accordance with Test Method E 77. Thermocouples shall be calibrated in accordance with Test Method E 220. Resistance thermometers shall comply with the requirements of Test Methods E 644 and Specification E 1137.

6.1.7 *Needle*—A flat-tipped, hardened steel needle with a cross-sectional area of $1.000 \pm 0.015 \text{ mm}^2$ (diameter of 1.120 to 1.137 mm) shall be used. The tip shall be free of burrs and be perpendicular to the axis of the rod. The needle shall protrude at least 2 mm from the end of the rod.

7. Sampling

7.1 Unless otherwise agreed upon between the seller and the purchaser, sample in accordance with the sections on General Sampling Procedures and Specific Sampling Procedures of Practice D 1898. Sampling based on engineering principles, prior to packaging, shall be considered an acceptable alternative.

8. Test Specimen

8.1 Use at least two specimens to test each sample. The specimen shall be flat, between 3 and 6.5 mm thick, and at least 10 by 10 mm in area or 10 mm in diameter. When necessary to use multiple layers, no more than three layers of material may be stacked in order to achieve the minimum thickness. The specimens may be cut from sheet or molded material. The type of mold and the molding process used to produce test specimens will affect the results obtained in the test. Molding conditions shall be in accordance with the standard for the material being tested or should be agreed upon between the cooperating laboratories.

NOTE 3—Discrepancies in test results due to variations in molding conditions may be minimized by annealing the test specimens before the test. Since different materials require different annealing conditions, annealing procedures shall be employed only if required by the material standard or if agreed upon between the cooperating laboratories.

9. Conditioning

9.1 If conditioning of the specimens is required, the test specimens shall be conditioned at $23 \pm 2^{\circ}\text{C}$ and at $50 \pm 5\%$ relative humidity for not less than 40 h in accordance with Practice D 618.

NOTE 4—Conditioning periods less than the 40 h, as specified by Practice D 618, may be used when it is shown that the Vicat softening temperature is not affected by the shorter conditioning time. Longer conditioning times may be required for some materials that take longer to reach temperature and humidity equilibrium. Refer to the applicable ASTM standards for those materials.

10. Procedure

10.1 Prepare the immersion bath so that the temperature of the heat-transfer medium is between 20 and 23°C at the start of the test unless previous tests have shown that for a particular material under test no error is introduced by starting at a higher temperature. The bath should be well stirred.

NOTE 5—Under certain conditions, it may be difficult to bring the temperature of the heat-transfer medium down to 20 to 23°C . In these cases, the test may be started with the bath temperature at 30°C . The selection of the starting temperature shall be agreed upon between the cooperating laboratories.

10.2 Place the specimen, which is at room temperature, on the specimen support so that it is approximately centered under the needle. The needle should not be nearer than 3 mm to the edge of the specimen. Gently lower the needle rod, without the extra mass, so that the needle rests on the surface of the specimen and holds it in position.

10.3 Position the temperature measuring device so that the sensing end is located within 10 mm from where the load is applied to the surface of the specimen. The sensing end should not touch the specimen.

10.4 Lower the assembly into the bath, taking care not to jar it in any way that would damage or dislodge the specimen.

10.5 Apply the extra mass required to increase the load on the specimen to $10 \pm 0.2 \text{ N}$ (Loading 1) or $50 \pm 1.0 \text{ N}$ (Loading 2). After a 5-min waiting period, set the penetration indicator to zero.

10.6 Start the temperature rise. The rate of temperature increase shall be either $50 \pm 5^{\circ}\text{C/h}$ (Rate A) or $120 \pm 10^{\circ}\text{C/h}$ (Rate B) and shall be uniform throughout the test. The Rate A heating requirement shall be considered to be met if over every 12-min interval during the test, the temperature of the bath rises $10 \pm 1^{\circ}\text{C}$ at each specimen location. The Rate B heating requirement shall be considered to be met if over every 6-min interval during the test, the temperature of the bath rises $12 \pm 1^{\circ}\text{C}$ at each specimen location. The selection of the rate of rise shall be agreed upon between cooperating laboratories. See Annex A1 for calibration of single temperature probe units.

10.7 Record the temperature of the bath when the needle has penetrated $1 \pm 0.01 \text{ mm}$ into the test specimen. Take care to ensure that an accurate reading of the temperature is made since the rate of penetration of the specimen will be increasing rapidly at this point.

10.8 Express the Vicat softening temperature as the arithmetic mean of the temperature of penetration of all specimens tested. If the range of penetration temperatures for the individual test specimens exceeds 2°C , record the individual results and repeat the test, using at least two new specimens.

NOTE 6—If a permanent record is desired, either read and record the penetration for each 5°C rise in temperature until the penetration reaches 0.4 mm, and at 2°C intervals thereafter, or attach a displacement transducer, having the same resolution as the gage, to each rod and continuously record the rate of penetration by means of a multichannel recorder or similar data-acquisition device.

NOTE 7—Some commercially available instruments record the time at which the penetration reaches a set depth. If this type of instrument is used, make a time-temperature calibration before the specimens are tested. This calibration compensates for slight variations in the heating rate. (**Warning**—Even though the variations may be within the specifications

set forth in 10.6, the compounded error over the range of the test can produce a substantial error in the Vicat softening temperature.)

11. Report

11.1 Report the following information:

- 11.1.1 Reference to this test method,
- 11.1.2 Complete identification of the material tested,
- 11.1.3 Method of preparing test specimens, including conditioning and annealing methods used,
- 11.1.4 Initial starting temperature,
- 11.1.5 Rate of temperature rise, Rate A (50°C/h) or Rate B (120°C/h),
- 11.1.6 Total load applied to the specimen, Loading 1 (10 ± 0.2 N) or Loading 2 (50 ± 1.0 N),
- 11.1.7 Thickness of the specimen and the number of layers of the material that were used,
- 11.1.8 Heat-transfer medium,
- 11.1.9 Vicat softening temperature, expressed as the arithmetic mean of the Vicat softening temperatures of the individual specimens, and
- 11.1.10 Any observations relating to the test.

12. Precision and Bias⁸

12.1 *Precision*—Tables 1 and 2 have been developed in accordance with Practice E 691. Table 1, for the case using Loading 1 (10 ± 0.2 N) and Heating Rate B (120 ± 10°C/h) is based on round-robin tests conducted in 1982 involving five materials and differing numbers of laboratories as noted in the table. Each laboratory obtained three test results for each material. Table 2, for the case using Loading 2 (50.0 ± 1.0 N) and Heating Rate A (50 ± 5°C/h) is based on round-robin tests conducted in 1994 involving 8 materials and six laboratories. Each laboratory obtained two test results for each material. In both cases, for each material, all of the individual specimens from all material samples were prepared by one source. Each test result was the average of two individual determinations.

⁸ Supporting data are available from ASTM Headquarters. Request RR:D20:1194.

NOTE 8—**Caution:** The following explanations of r and R (see 12.1.1-12.1.1.3) are intended only to present a meaningful way of considering the approximate precision of this test method. The data given in Tables 1 and 2 should not be applied rigorously to the acceptance or rejection of material, as those data are specific to the round-robin test and may not be representative of other lots, conditions, materials, or laboratories. Users of this test method should apply the principles outlined in Practice E 691 to generate data specific to their laboratory and materials, or between specific laboratories. The principles of 12.1.1-12.1.1.3 would then be valid for such data.

12.1.1 *Concept of r and R* —If S_r and S_R have been calculated from a large enough body of data, and for test results that were averages from testing two specimens, the following applies:

12.1.1.1 *Repeatability, r* —In comparing two test results for the same material obtained by the same operator using the same equipment on the same day, the two test results obtained within one laboratory shall be judged as not equivalent if they differ by more than the “ r ” value for that material. “ r ” is the interval representing the critical difference between two test results for the same material, obtained by the same operator using the same equipment on the same day in the same laboratory.

12.1.1.2 *Reproducibility, R* —In comparing two test results for the same material obtained by different operators using different equipment in different laboratories on different days, the two test results obtained by different laboratories shall be judged not equivalent if they differ by more than the “ R ” value for that material. “ R ” is the interval representing the critical difference between two test results for the same material, obtained by different operators using different equipment in different laboratories.

12.1.1.3 Any judgment in accordance with 12.1.1 or 12.1.1.1 would have an approximate 95 % (0.95) probability of being correct.

12.2 *Bias*—There are no recognized standards by which to estimate the bias of this test method.

13. Keywords

13.1 plastics; thermoplastics; Vicat softening temperature

TABLE 1 Vicat Softening Temperature Using Loading 1 and Rate B, Values Expressed in Units of °C

Material	Average	S_r^A	S_R^B	r^C	R^D	Number of Participating
						Laboratories
Ethylene vinyl acetate	72.4	1.44	2.29	4.03	6.40	10
Polystyrene	97.3	0.68	2.36	1.91	6.62	10
High-density polyethylene	127.9	1.04	2.73	2.90	7.63	10
Polypropylene	152.5	1.13	2.83	3.16	7.91	10
Nylon 66	251.2	0.70	5.06	1.96	14.16	7

^A S_r = within-laboratory standard deviation of the average.

^B S_R = between-laboratories standard deviation of the average.

^C r = within-laboratory repeatability limit = 2.8 S_r .

^D R = between-laboratories reproducibility limit + 2.8 S_R .

TABLE 2 Vicat Softening Temperature Using Loading 2 and Rate A, Values Expressed in Units of °C

Material	Average	S_f^A	S_R^B	r^C	R^D
Polypropylene (PP0343)	56.2	1.07	1.86	2.99	5.22
Polypropylene (PP0114)	92.5	1.47	4.08	4.12	11.44
Impact Modified Acrylic (PMMA0230V1)	94.1	0.32	1.96	0.91	5.48
ABS	94.4	0.62	1.61	1.74	4.52
High Heat ABS (ABS0135)	100.8	0.34	1.53	0.95	4.29
Unmodified Acrylic (PMMA0141V3)	105.1	0.44	1.48	1.23	4.15
Polycarbonate (PC0136)	143.6	0.19	1.24	0.53	3.48
Polycarbonate (PC0123)	143.8	0.38	1.03	1.05	2.89

^A S_f = within-laboratory standard deviation for the indicated material. It is obtained by pooling the within-laboratory standard deviations of the test results from all of the participating laboratories:

$$S_f = \left[\frac{(S_1)^2 + \dots + (S_n)^2}{n} \right]^{1/2}$$

^B S_R = between-laboratories reproducibility, expressed as standard deviation: $S_R = [S_f^2 + S_L^2]^{1/2}$ where S_L = standard deviation of laboratory means.

^C r = within-laboratory critical interval between two test results = $2.8 \times S_f$.

^D R = between-laboratories critical interval between two test results = $2.8 \times S_R$.

ANNEX

(Mandatory Information)

A1. CALIBRATION OF SINGLE-(CENTRALIZED) TEMPERATURE PROBE UNITS

A1.1 If the unit in operation is of the type that has only one temperature probe in the bath, and this probe is monitored to record the softening temperature of the specimen at all the stations in the unit, then the following calibration and checks must be undertaken to ensure comparable results with units that have a temperature probe at each station.

A1.2 This procedure must be performed annually as a minimum to ensure proper temperature distribution and accuracy of probe and display.

A1.3 Calibration will require the use of temperature meter and probe traceable to NIST, with accuracy and display resolution of 0.1°C or better, a stopwatch, and any tools needed to open and adjust the unit.

A1.3.1 Low-temperature calibration of the unit is accomplished by placing the NIST-traceable probe within 10 mm of specimen height, in the bath at three different points in the bath. The three points will be at the center and left and right ends of the bath. Start with the station closest to the centralized probe, while the unit is programmed to maintain a constant temperature between 20 and 50°C, with all stirrers operating. Allow the bath to stabilize for a minimum of 5 min. Read and record the readout of the calibrated probe and the unit's internal temperature display to the nearest 0.1°C. Make any necessary adjustments to the unit's temperature controller to bring the bath to $\pm 0.1^\circ\text{C}$ of the bath set point, allowing a stabilization time of a minimum of 5 min between adjustment(s) and readings. Once the calibrated probe indicates the bath is at the set point, make adjustments to the centralized probe's display as necessary.

A1.3.1.1 Move the NIST-traceable probe to the other two points maintaining the probe within 10 mm of specimen height. Read and record the temperatures at these points, after allowing the probe to stabilize a minimum of 5 min.

A1.3.2 High-temperature calibration will be accomplished by programming the unit to maintain an elevated temperature near, but not exceeding, the highest temperature allowed by the

heat transfer media. All covers and stations must be in place and stirrer motors operating. Place the NIST probe within 10 mm of specimen height at the station closest to the centralized probe, and allow the bath to stabilize for a minimum of 5 min. Read and record the readout of the calibrated probe and the unit internal temperature display to the nearest 0.1°C. Make any necessary adjustments to the unit's temperature controller to bring the bath to $\pm 0.1^\circ\text{C}$ of the bath set point, allowing a stabilization time of a minimum of 5 min between adjustment(s) and readings. Once the calibrated probe indicates the bath is at the set point make adjustments to the centralized probe's display as necessary.

A1.3.2.1 Move the NIST-traceable probe to the other two points maintaining the probe within 10 mm of specimen height. Read and record the temperatures at these points, after allowing the probe to stabilize for a minimum of 5 min.

A1.3.3 Evaluate the data from each of the three points in the bath at both low and high temperature. If any point is greater than $\pm 0.5^\circ\text{C}$ from the set point, have the unit serviced or repaired to correct this error. If it is not possible to correct the bath uniformity to less than 0.5°C, then a thermal sensing device must be placed at each station and used to record the temperature of the bath at the time of deflection while running tests. The unit may be electronically modified or the use of glass thermometers (as outlined in 6.1.6) may be placed at each station and manually read and recorded at the moment of specimen deflection.

A1.3.4 If the steps given in A1.3.1-A1.3.2.1 have been taken and successfully completed, cool the bath down to a normal start temperature and allow the bath to stabilize. Place the NIST probe at the point in the bath that the preceding gathered data shows the greatest error. Start a test at 120°C/h or 50°C/h. Read and record the temperature of both the unit's display and the readout of the NIST probe. An offset of 10 to 15 s between the two readings is acceptable as long as this interval is maintained throughout this test. Start the stopwatch

when the first temperature is recorded. Read and record the temperature of the unit's display and the NIST probe, maintaining any delay interval, if used, every 5 min for 1 h.

A1.3.5 Evaluate the data acquired during the test given in A1.3.4. Ensure that the temperature of the bath is rising at the correct rate as outlined in 10.6, at both the centralized probe and the other selected test point. If either is outside the limits

for the rate of rise, the unit must be serviced and rechecked before further use. If a unit fails to pass this calibration test the unit must be serviced or replaced. Placing a temperature sensing device at each station will not correct the problem observed in A1.3.4, as the unit's rate of rise is outside the tolerances of this test method.

APPENDIXES

(Nonmandatory Information)

X1. PROCEDURE FOR DETERMINATION OF CORRECT SPECIMEN LOADING UTILIZING EQUILIBRIUM WEIGHING OF THE LOADING ROD

X1.1 Apparatus:

X1.1.1 The apparatus is constructed essentially as shown in Fig. X1.1 and consists of the following:

X1.1.1.1 Laboratory Scale, having a resolution of at least 0.1 g.

X1.1.1.2 Platform Assembly, for supporting the test unit above the scale.

X1.1.1.3 Bridge Platform, for supporting the loading rod on the scale.

X1.2 Procedure:

X1.2.1 Calculate the load required to apply the desired force on the specimen using the equation given in 6.1.5.

X1.2.2 Level the mounting assembly on top of the tester. Shim or clamp if necessary for firm seating.

X1.2.3 Level the scale.

X1.2.4 Position the test frame on the cross bar above the scale.

X1.2.5 Lubricate the rod and guide hole surfaces with a light oil.

X1.2.6 Lift the loading rod and put the bridge in place on

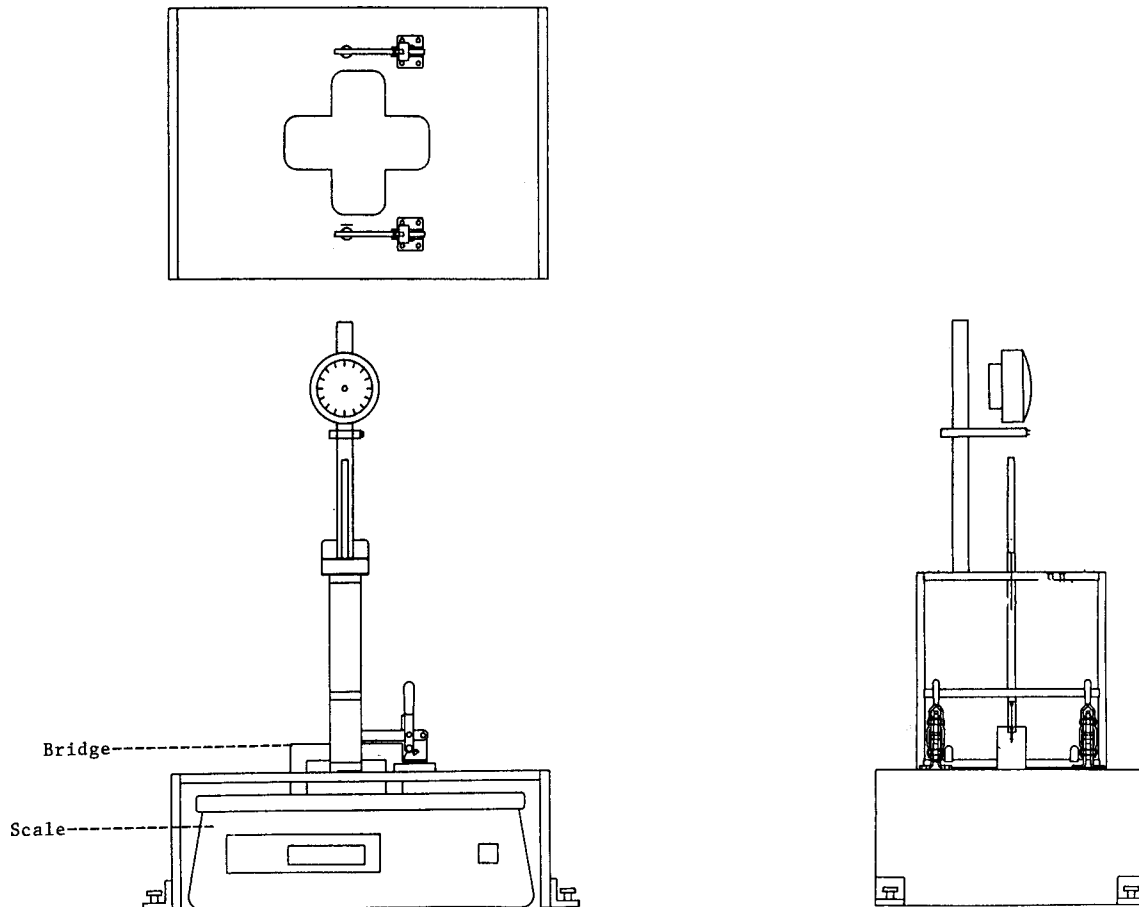

FIG. X1.1 Calibration Apparatus Using a Laboratory Scale

the scale pan so that it will support the loading rod. The bridge height dimension is such that it supports the rod approximately 2 mm (or the thickness of the test specimen normally used) above the base of the test frame.

X1.2.7 Determine the mass of the bridge.

X1.2.8 With the deflector arm in position over the dial gage, lower the rod to the bridge and release it very gently. In this position, the dial gage should be adjusted so that it is approximately in the middle of its travel, with at least 1.0 mm

of travel left to allow for penetration of the specimen during a normal test.

X1.2.9 Record the force in grams. This amount, when converted to newtons, should equal $(F - F_s)$ as calculated in 6.1.5.

NOTE X1.1—The test units (rod, guide surface, and dial gage) shall be clean and free of any surface imperfections, etc., to achieve precision in calibration and normal test use.

X2. PROCEDURE FOR DETERMINATION OF CORRECT SPECIMEN LOADING BY WEIGHING THE APPLIED LOAD WITH A TENSION-TESTING MACHINE

X2.1 Apparatus:

X2.1.1 The apparatus is constructed essentially as shown in Fig. X2.1 and consists of the following:

X2.1.1.1 *Tension-Testing Machine*, of the constant-rate-of-jaw-separation type, equipped with devices for recording the tensile load and the grip separation. The testing machine used should be capable of measuring loads of at least 2000 g. The rate of separation of the jaws should be capable of adjustment to 0.51 mm/min.

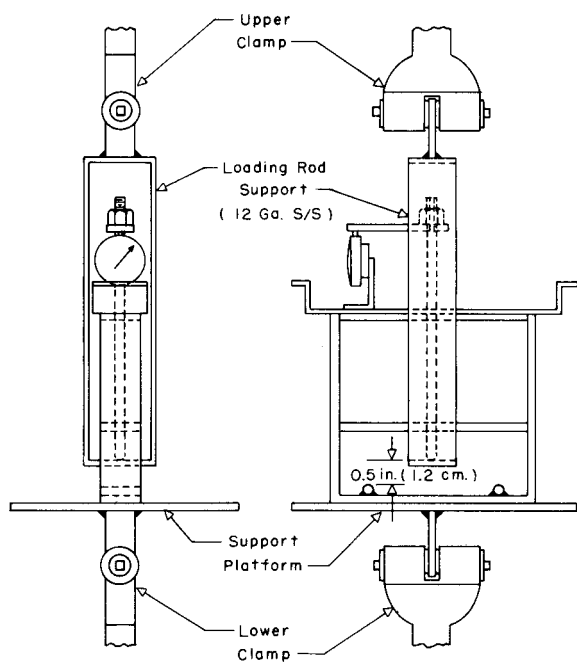

FIG. X2.1 Calibration Apparatus Using a Tensile Machine

X2.1.1.2 *Platform*, square, approximately 203 by 203 mm, to be mounted on the lower crosshead of the tensile machine to support the deflection temperature test unit.

X2.1.1.3 *Loading Rod Support*—A saddle-like device to be clamped in the upper grips of the tensile machine so that it extends under the bottom tip of the loading rod.

X2.2 Procedure:

NOTE X2.1—This technique is applicable to dial-type test instruments only.

X2.2.1 Mount the support platform in the lower cross-head clamps.

X2.2.2 Fit the loading rod support into the upper clamps and calibrate the tensile-testing machine.

X2.2.3 Secure the Vicat softening point test unit on the support platform and adjust the loading rod support so that the tip of the loading rod is 2.54 mm from the top of the specimen support.

X2.2.4 Lubricate the rod and guide hole surfaces with light oil.

X2.2.5 Adjust the dial gage so that it reads zero, then turn the nut on top of the loading rod clockwise until the deflector arm almost makes contact with the contact arm on top of the dial gage.

X2.2.6 Start the lower crosshead in the up direction at the rate of 0.51 mm/min. This in effect causes the loading rod to move down as in an actual test. When the pointer on the dial gage shows movement, activate the chart drive at the rate of 25.4 mm/min.

X2.2.7 Record the force, g, at 1.00 ± 0.05 -mm penetration.

X2.2.8 Adjust the mass of the loading rod required to give the desired maximum load according to the equation given in 6.1.5.

X3. PROCEDURE FOR VERIFYING THE CALIBRATION OF PENETRATION MEASURING DEVICES USING GAGE BLOCKS

X3.1 This procedure is intended to provide a method of verifying the calibration of penetration measuring devices typically found on vicat softening temperature measuring instruments. It is not a calibration method. If the user finds that the measuring device on one or more test stations is out of calibration, the manufacturer of the instrument, or a qualified

calibration service company, should be consulted to have the problem corrected. This procedure may be used for dial indicator, LVDT and encoder-type penetration-measuring devices.

X3.2 Remove the test frame from the bath. Wipe excess

heat transfer medium from the frames and place on a sturdy, level surface. If it is not possible to remove the test frame from the bath, the frame may be positioned on top of the instrument, providing the frame is level during the verification procedure so that the loading rod will apply its full load as it would during a test.

X3.3 Thoroughly clean the needle tip and the surface of the frame where the specimen is normally positioned.

X3.4 Select a minimum of two gage blocks that, when stacked together, are comparable in height to a typical test specimen. At least one of the gage blocks should be a 1.00-mm block.

NOTE X3.1—If a 1.00-mm gage block is not available, a 0.040-in. (1.016-mm) gage block may be substituted.

X3.5 Place the stacked blocks in the test frame where the specimen is normally positioned. Lower the loading rod onto the gage blocks in such a way that the penetrating needle is in

the middle of the block. Add the required weight to the rod to apply force to the block (either 10 or 50 N), simulating test conditions. Zero the indicator or record the reading on the display.

NOTE X3.2—Care must be taken to avoid damaging the gage blocks when using the 50-N force.

X3.6 Lift the loading rod and remove the 1.00-mm (or 0.040-in.) block from beneath the rod and lower the rod onto the remaining gage block. Do not change the position of the remaining gage block. Record the reading on the indicator. The change in the reading should be equal to 1.00 ± 0.01 mm (or 0.040 in.).

X3.7 Repeat the procedure at least twice to ensure repeatability. Intermediate readings can be verified in a similar manner by using different size gage blocks.

X3.8 Repeat this procedure for all of the instrument's penetration measuring devices.

SUMMARY OF CHANGES

This section identifies the location of selected changes to this test method. For the convenience of the user, Committee D20 has highlighted those changes that may impact the use of this test method. This section may include descriptions of the changes, or the reasons for the changes, or both.

D 1525 – 97a:

- (1) Appendix X3 added.
- (2) Revised Section 12, Precision and Bias, as a result of additional data obtained from a new round robin study.

D 1525 – 98:

- (1) Section 6.1 was revised to add needle diameter.

D 1525 – 00:

- (1) Added Annex A1 and reference to Annex in 10.6.

ASTM International takes no position respecting the validity of any patent rights asserted in connection with any item mentioned in this standard. Users of this standard are expressly advised that determination of the validity of any such patent rights, and the risk of infringement of such rights, are entirely their own responsibility.

This standard is subject to revision at any time by the responsible technical committee and must be reviewed every five years and if not revised, either reapproved or withdrawn. Your comments are invited either for revision of this standard or for additional standards and should be addressed to ASTM International Headquarters. Your comments will receive careful consideration at a meeting of the responsible technical committee, which you may attend. If you feel that your comments have not received a fair hearing you should make your views known to the ASTM Committee on Standards, at the address shown below.

This standard is copyrighted by ASTM International, 100 Barr Harbor Drive, PO Box C700, West Conshohocken, PA 19428-2959, United States. Individual reprints (single or multiple copies) of this standard may be obtained by contacting ASTM at the above address or at 610-832-9585 (phone), 610-832-9555 (fax), or service@astm.org (e-mail); or through the ASTM website (www.astm.org).